

Heated retrofit drains TOPWET TWE RETRO

BASIC INFORMATION

purpose	direct connection to existing roof drains or vertical rainwater pipes with electric heating
material	drain body – polyamide PA6, dome – polyamide PA6, retrofit seal – EPDM
integrated connection sleeve	BIT – modified bituminous APP strip, TPO – thermoplastic (flexible) polyolefin, EPDM – synthetic rubber foil, PVC - mPVC based foil, STE – of liquid sealing, VAP - self adhered vapour barrier comprised of SBS modified bitumen adhesive, laminated with high-density polyethylene top surface
colour	grey
certification	ASME A112.6.4-2003
manufacturer	TOPWET s.r.o., náměstí Viléma Mrštíka 62, 664 81 Ostrovačice, Czech Republic

TECHNICAL PARAMETERS

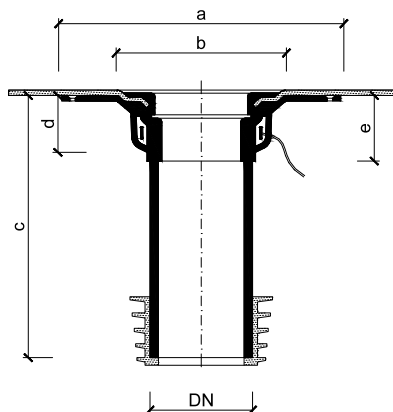

Heated retrofit drains for heat-insulated roofs

Type	DN	Dimensions [in]				
		a	b	c*	d	e
TWE RETRO 3	3	13	8	16	3 1/2	3 1/2
TWE RETRO 4	4	13	8	16	3 1/2	3 1/2
TWE RETRO 5	5	13	8	16	3 1/2	3 1/2
TWE RETRO 6	6	13	8	16	3 1/2	3 1/2

* optionally extension up to 60" to order

HEATING PARAMETERS

- Connection is made in the electrical box under the roof structure
- The supply cable length for the outlet is 4.9 ft (wire NM-B 14-2)
- Wiring connection: brown – guard black – phase, white - neutral
- Alternating voltage: 110 V, 60 Hz
- Input: variable, according to the ambient ambient temperature, approx: 10 W at 68°F / 14 W at 32°C / 20 W at -4°F
- Max. current surge: 120 mA
- Enclosure rating: IP 67

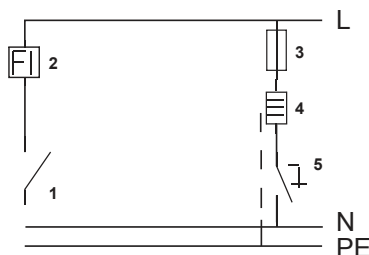

- 1 – main switch
- 2 – current protection
- 3 – circuit breaker
- 4 – roof drain
- 5 – thermostat or switch
- L – phase (black)
- N – neutral (blue)
- PE – guard (green and yellow)